

**1224DWR • 24" Solid Refrigerator Drawers • 1000 Series**

**FEATURES & BENEFITS**



**STAINLESS SOLID**



**INTEGRATED SOLID**

<b>PERFORMANCE</b>	<ul style="list-style-type: none"> <li>• Volume of 5.4 cu ft holds up to 98 bottles (12 oz) or 150 cans (12 oz)</li> <li>• Digital Touch Pad Control</li> <li>• Temperature range: 34°F - 45°F</li> <li>• Passive cooling system</li> </ul>
<b>INTERIOR/EXTERIOR</b>	<ul style="list-style-type: none"> <li>• Black interior is illuminated with LED lighting</li> <li>• Equipped with 2 full-extension robust stainless drawers</li> <li>• Standard commercial stainless steel handle is interchangeable with professional handle accessory</li> <li>• The lower drawer is large enough to fit 2 one-gallon containers with additional space for more storage</li> </ul>
<b>INTEGRATION</b>	<ul style="list-style-type: none"> <li>• Unit is designed to be built-in or can be freestanding with the freestanding accessory kit</li> <li>• Integrated model requires 3/4" custom door panel (panels not supplied by U-Line)</li> <li>• Four independently adjustable leveling legs provide a precise undercounter fit</li> <li>• Available in the following finishes: Stainless or Integrated</li> </ul>

**MODEL DETAILS**

Model	Voltage/Hz	Door Swing	Finish	Shipping Weight
U-1224DWRS-00B	115 / 60	Drawers	Stainless Solid	142 lb
U-1224DWRINT-00B	115 / 60	Drawers	Integrated Solid	134 lb

**ACCESSORIES**

Model	Description	Finish	Shipping Weight
80-54289-00	Commercial Drawer Handle, 7/8" Diameter	Stainless	2 lb
80-54462-00	Professional Drawer Handle, 1 1/4" Diameter	Stainless	2 lb
U-FSK-B	Freestanding Kit	Black	3 lb
80-54362-00	1k Top Drawer Slide and Divide Bin Organizer	N/A	3 lb

**1000 Series • 24" Solid Refrigerator Drawers • 1224DWR**
**DIMENSIONS**

Dimensions shown apply to all finishes, including Integrated (INT) models with 3/4" integrated panel/frame installed.

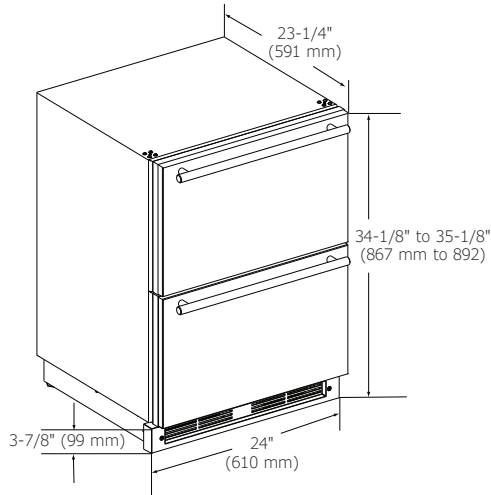
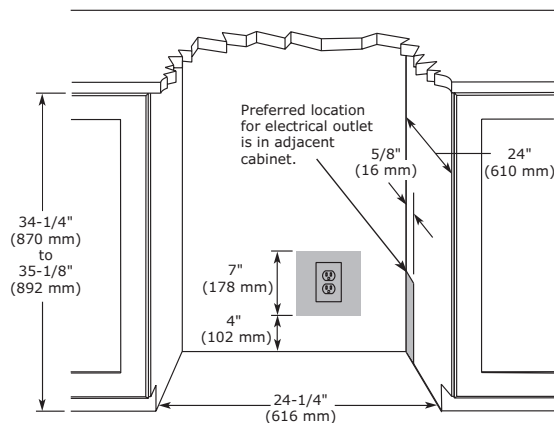

**CABINET CUT-OUT**

**INSTALLATION NOTES**

Cutout includes the additional 1/4" width overall to ensure proper installation.

No additional clearance around sides, top or rear of unit is needed for ventilation.

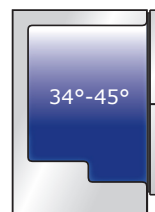
**SPECIFICATIONS**

Model	1224DWR
Amps: Running	1.2
Capacity: Bottle (12 oz)	98
Capacity: Can (12 oz)	150
Capacity: Volume (cu ft)	5.4
Control Type	Digital Touch Pad
Dimensions: Product Depth	23 3/4" / 591 mm
Dimensions: Product Height	34 1/8" / 867 mm
Dimensions: Product Width	24" / 610 mm
Energy Consumption: Avg. Per Year	305 kWh
ENERGY STAR	No
Panel Height	15" / 381 mm
Panel Thickness	3/4" / 20 mm
Panel Type	Solid Panel
Panel Width	23 3/4" / 603 mm
Product Weight: Max	132 lb
Refrigerant Type	R600a
Sabbath (Star K Certified)	Yes
Temperature Range	34°F - 45°F

**COOLING SYSTEM**

**ELECTRICAL REQUIREMENTS**

This unit requires a grounded, polarized 115 VAC, 60 Hz, 15 A power supply (normal household current).

Please visit [U-Line.com](http://U-Line.com) to view this model's User Guide. All specifications are subject to change without notice.

