

COASTER[®]
FINE FURNITURE

300279T
TWIN SIZE BED

ASSEMBLY INSTRUCTION
COASTER FINE FURNITURE



www.coastercompany.com

08/07/2014

ASSEMBLY INSTRUCTIONS

ASSEMBLY TIPS:

1. Remove hardware from box and sort by size.
2. Please check to see that all hardware and parts are present prior to start of assembly.
3. Please follow attached instructions in the same sequence as numbered to assure fast & easy assembly.



Warning !

1. Don't attempt to repair or modify parts that are broken or defective . Please contact the store immediately.
2. This product is for home use only and not intended for commercial establishment.

PARTS IDENTIFICATION

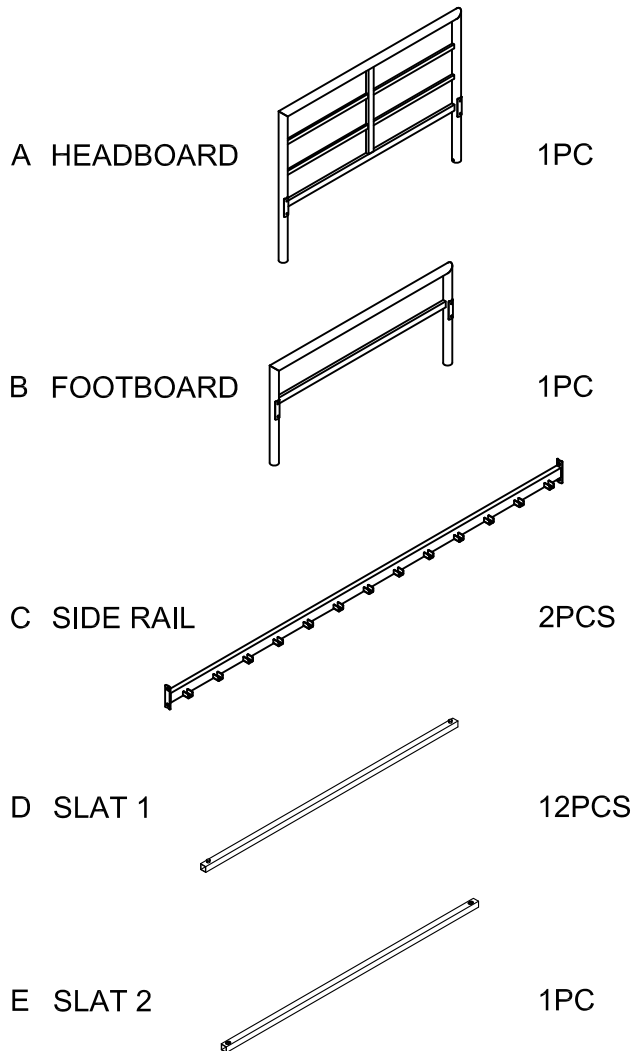

Z HARDWARE LIST:

NO	DESCRIPTION	FIGURE	Q`TY
1	SMALL BOLT 1/4"X5/8"		8pcs
2	LARGE BOLT 1/4"X1 1/8"		2pcs
3	WASHER		10pcs
4	ALLEN WRENCH		1pc

ASSEMBLY

Do not fully tighten all bolts until assembly is complete. This will help all parts to assemble properly.

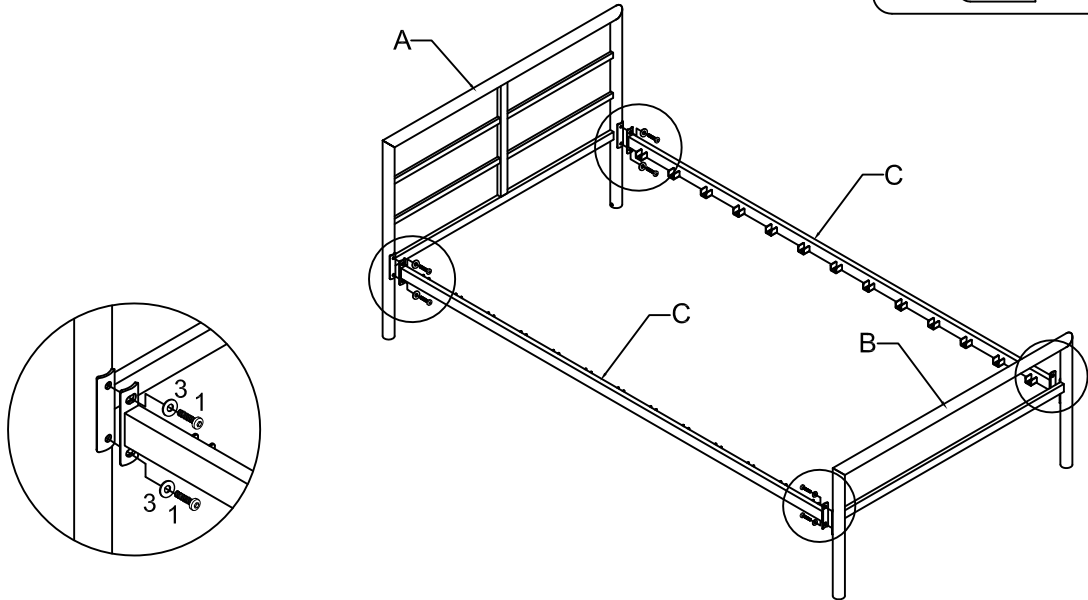
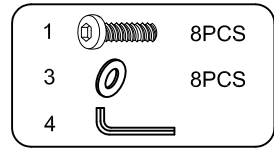

Step 1: Align and attach the side rails (C), headboard (A) and footboard (B) using bolt (1), washer (4), tighten with allen wrench. As shown on the drawing.

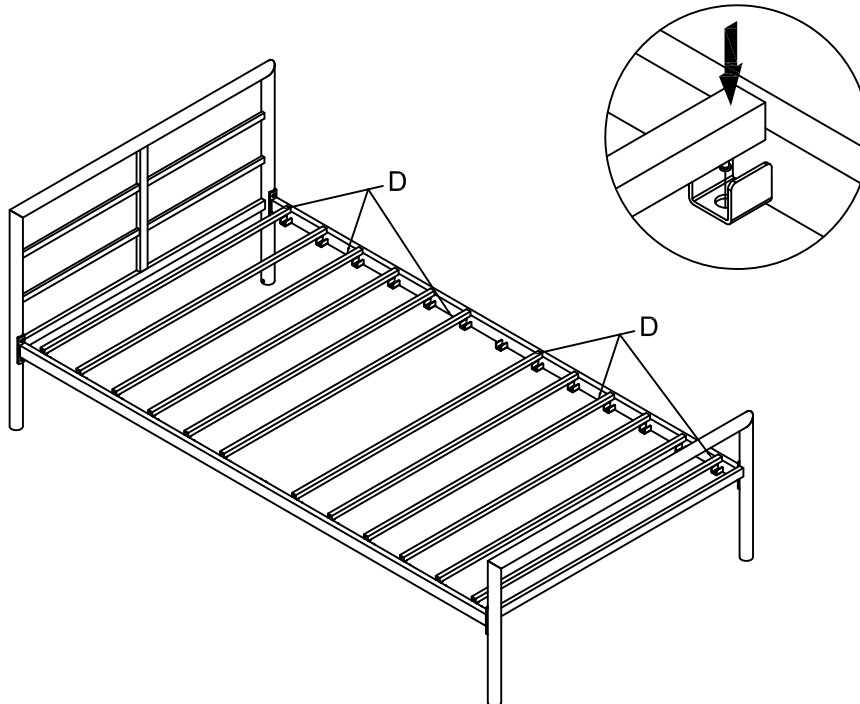

Step 2: Align and attach slats 1 (D) to the side rails (C). As shown on the drawing.



Step 3: Align and attach the legs to slat 2 (E) using bolt (3), washer (4) tighten with allen wrench. As shown on the drawing.

- | | | |
|---|-------------------------------------------------------------------------------------|------|
| 2 |  | 2PCS |
| 3 |  | 2PCS |
| 4 |  | |

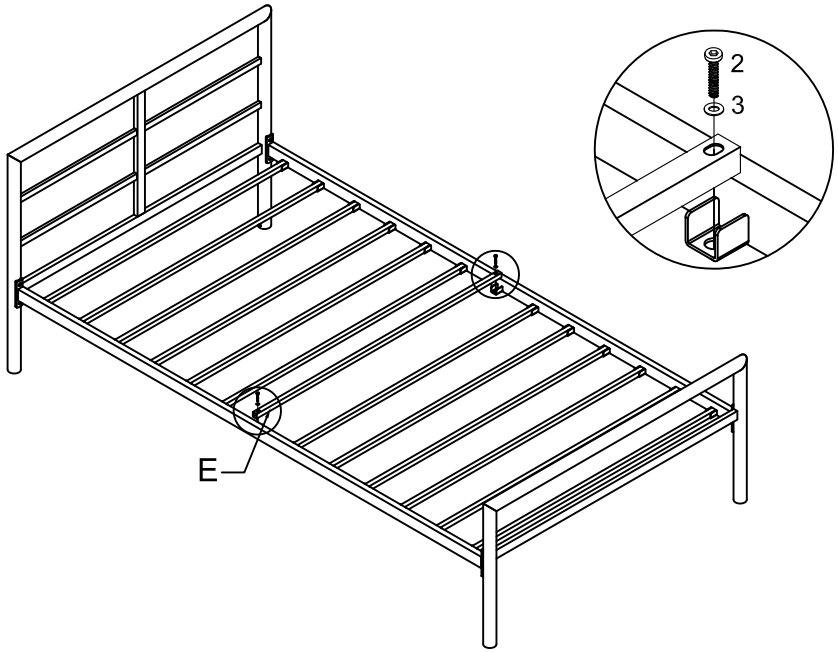

Step 4: Completed.

