

# T24UC915DS

## UNDER-COUNTER DOUBLE DRAWER REFRIGERATOR / FREEZER

MASTERPIECE® SERIES HANDLE



Also Available:  
 T24UC925DS – With Professional Series Handle  
 T24UC905DP – Custom Panel-Ready

### FEATURES & BENEFITS

- Customizable cooling modes in refrigerator drawer — Refrigerator, Pantry, Bar and Quick Chill
- SoftClose® drawers for ultra-smooth closing
- Customizable drawer dividers and shelving
- Filtered Automatic Ice Maker
- LED Lighting
- Drawer mats keep items from sliding and remove for easy cleaning
- Touch electronic controls for temperature management

### GENERAL PROPERTIES

SoftClose® Drawers	Yes
Lighting	LED Lighting
Customizable Aluminum Dividers / Shelving	Yes
Removable Drawer Mats	Yes
Filtered Automatic Ice Maker	Yes
Full Extension Drawers	Yes
Drawer Open Alarm	Yes
Quick Chill	Yes
Touch Electronic Controls	Yes
STAR-K Certified Sabbath Mode	Yes

### CAPACITY

Total Capacity (cu. ft.)	4.3 cu. ft.
--------------------------	-------------

### TEMPERATURE RANGES

Refrigerator	33°F (0.5°C) to 47°F (8.5°C)
Freezer	-8°F (-22°C) to 6°F (-14.5°C)
Pre-Set Cooling Modes	Refrigerator 37°F (3°C) Pantry 44°F (7°C) Bar 34°F (1°C)
Quick Chill	Refrigerator 33°F (0.5°C) for approximately 24 hours Freezer -8°F (-22°C) for approximately 24 hours

### TECHNICAL DETAILS

Watts (W) / Current (A) / Volts (V)	150 W / 15 Amp / 115 V
Frequency (Hz)	60 Hz
Power Cord Length (in.)	60"
Plug Type	120V 3-Wire

### DIMENSIONS & WEIGHT

Appliance Dimensions (H x W x D) (in.)	34 1/8"* x 23 7/8" x 23 5/8"
Required Cutout Size (H x W x D) (in.)	34 1/2"–35 1/8" x 24" x 24"
Net / Gross Weight (lbs.)	144.5 / 155.5 lbs.

### EFFICIENCY

ENERGY STAR® Qualified	Yes
Annual Energy Consumption	442 kWh

### WARRANTY

Limited, Entire Appliance, Parts and Labor on any Part of the Refrigerator that Fails Because of a Manufacturing Defect

2 Year

Limited Warranty for Sealed Refrigeration System\*; Parts and Labor  
 3rd to 6th Year

Limited Warranty for Sealed Refrigeration System\*; Parts Only  
 7th to 12th Year

\*Height adjustable + 1/2" (13 mm) with legs fully extended

\*\*Sealed refrigeration system includes compressor, evaporator, condenser, dryer / strainer and connection tubing

# T24UC915DS

## UNDER-COUNTER DOUBLE DRAWER REFRIGERATOR / FREEZER

MASTERPIECE® SERIES HANDLE



### DOUBLE DRAWER REFRIGERATOR / FREEZER PRODUCT DIMENSIONS

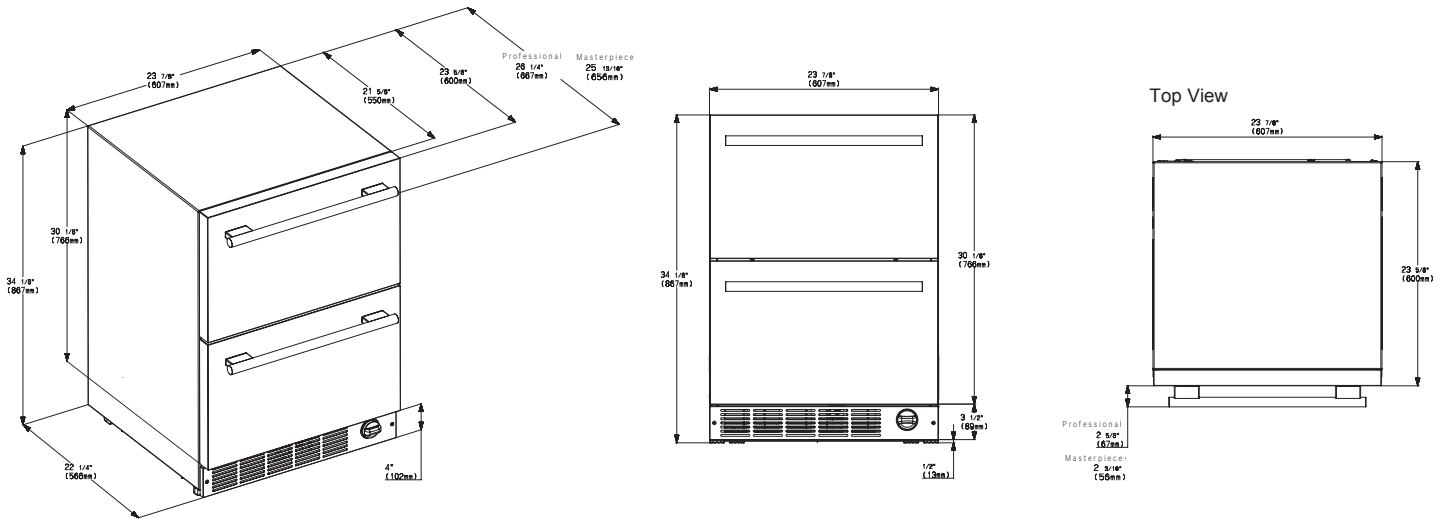

### DOUBLE DRAWER REFRIGERATOR / FREEZER CUTOUT DIMENSIONS

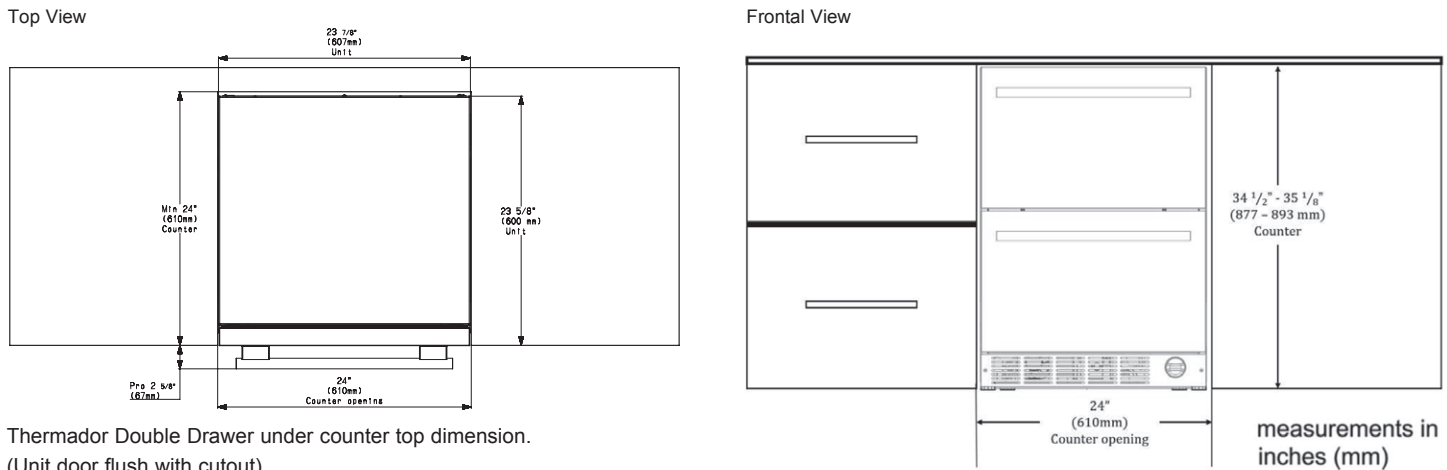

### DOUBLE DRAWER REFRIGERATOR / FREEZER CLEARANCE DIMENSIONS

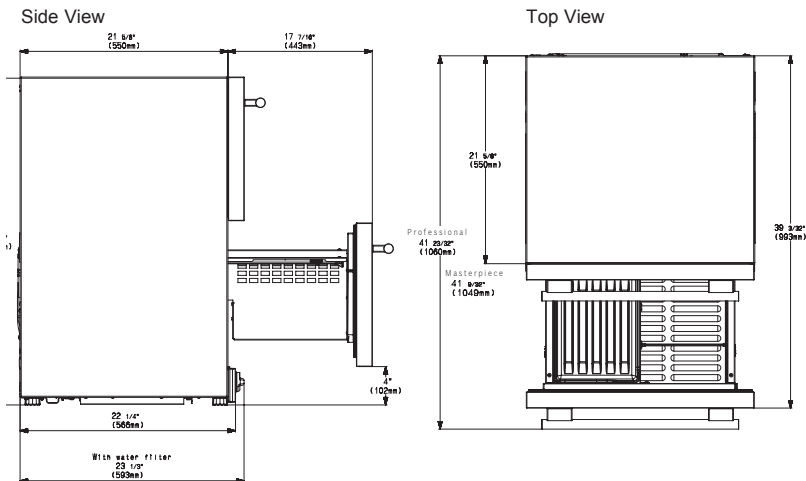

### ACCESSORIES (OPTIONAL)

#### FILTERS



UCTRFLTR10  
Water Filter

# T24UC915DS

## UNDER-COUNTER DOUBLE DRAWER REFRIGERATOR / FREEZER

MASTERPIECE® SERIES HANDLE



### DOUBLE DRAWER REFRIGERATOR / FREEZER SIDE-BY-SIDE INSTALLATION

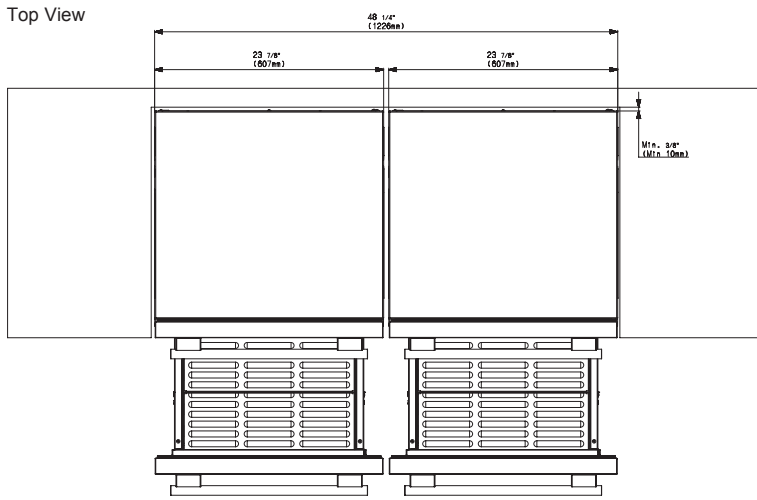

### DOUBLE DRAWER REFRIGERATOR / FREEZER CUTOUT DIMENSIONS & ELECTRICAL LOCATION

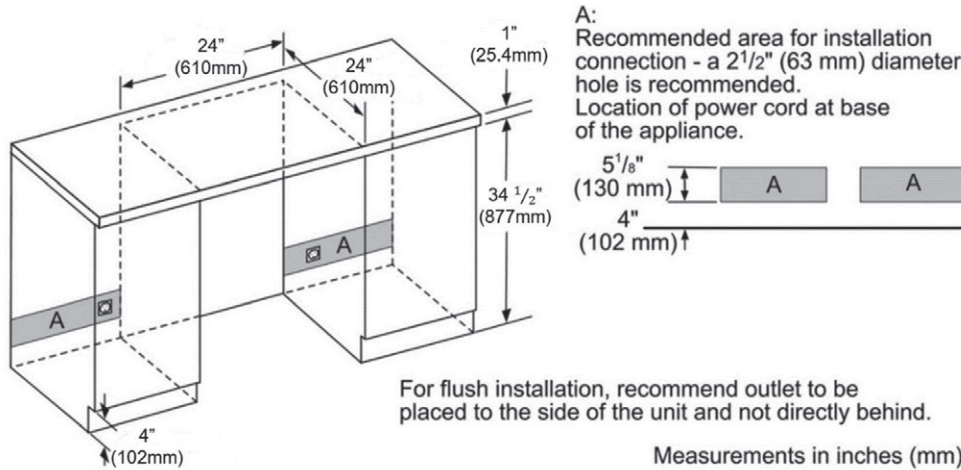

These warranties give you specific legal rights and you may have other rights that vary from state to state. Limited warranty from date of purchase. For complete warranty details, refer to your Use & Care manual, or ask your dealer.

Specifications are for planning purposes only. Refer to installation instructions and consult your countertop supplier prior to making counter opening. Consult with a heating and ventilation engineer for your specific ventilation requirements. For the most detailed information, refer to installation instructions accompanying product or write to Thermador indicating the model number. Specifications are correct at time of printing. Thermador reserves the right to change product specifications or design without notice. Some models are certified for use in Canada. Thermador is not responsible for products that are transported from the U.S. for use in Canada.