

**REFRIGERATOR MANUFACTURER**  
**Turbo air**  
 more durable, efficient, beautiful

4184 E. Conant St.  
 Long Beach, CA 90808  
 Tel. 310-900-1000  
 Fax. 310-900-1077  
[www.turboairinc.com](http://www.turboairinc.com)

Project :	
Model # :	
Item # :	Qty :
Available W/H :	
Approval :	

## Drop-in Type Bakery Display Cases

Refrigerated  
Bakery Cases

### Patented Self-Cleaning Condenser



This product is equipped with a fine mesh filter to the front of the condenser to catch dust, and a rotating brush that moves up and down daily to remove excess buildup outward and away.

**Model : TBP36-46FDN**



\* Bottom portion will not be visible after installation

## ≡ FEATURES & BENEFITS ≡

- Self-Cleaning Condenser**  
 The accumulation of dust in the condenser can cause the failure or breakdown of refrigerators. Refrigerators run normally until they reach a certain level of accumulation. At some point, when they are over the limit, their performance drops quickly resulting in damage to, or disposal of the stored products inside. The Self-Cleaning Condenser device keeps the condenser clean and prevents system failure by automatically brushing daily.
- Hydrocarbon refrigerants (R-290)**  
 With innovative and eco-friendly technology, Turbo Air brings you hydrocarbon refrigerators designed to meet DOE's Energy Conservation Standards in 2017 and to use EPA's SNAP Program approved HC refrigerants. Hydrocarbon refrigerants do not deplete the ozone layer and have very low contribution to global warming (ODP-0, GWP-3).
- Attractive, elegant, glass sided Euro design**  
 Straight, tempered front & side glass with minimal frame provide full product visibility to optimize display effects. Its elegant contemporary euro design and luxurious colored case will not only enhance any store atmosphere but also will keep product presentation at its best and most beautiful.
- High-density polyurethane insulation**  
 The entire cabinet structure is foamed-in-place using high density, CFC free polyurethane insulation.
- Digital temperature controller**
- Low-E coated double pane glass is tempered for safety**
- Adjustable, tempered glass shelves with stainless steel front and back edges**
- Stainless steel floor and airflow grille**
- Sliding rear doors and front glass for product loading & unloading**
- Rear access to compressor compartment for quick and easy service**
- Refrigerated bakery case holds avg. 33°F ~ 41°F for fresher bakery products**

**NATURAL Refrigerant**



Model	CU./FT.	# of Shelves	HP	AMPS	Net Weight (lbs.)	L x D x H (inches)
TBP36-46FDN	9	1	1/3	6.3	327	37 x 29 <sup>3</sup> / <sub>4</sub> x 46 <sup>1</sup> / <sub>4</sub>

# Drop-in Type Bakery Display Cases

Refrigerated  
Bakery Cases

## Model : TBP36-46FDN

ELECTRICAL DATA	
Voltage	115/60/1
Plug Type	Ⓢ NEMA 5-15P
Full Load Amperes	6.3
Compressor HP	1/3
Refrigerant	R-290
DIMENSIONAL DATA	
Net Capacity (cu. ft.)	9
Ext. Length Overall (in.)	37 <sup>3</sup> / <sub>8</sub> (940mm)
Ext. Depth Overall (in.)	29 <sup>3</sup> / <sub>4</sub> (755mm)
Ext. Height Overall (in.)	46 <sup>1</sup> / <sub>4</sub> (1175mm)
Shelf Size (in.)	32 <sup>3</sup> / <sub>8</sub> x 15
# of Shelves	1
Power Cord Length (in.)	118 <sup>1</sup> / <sub>8</sub> (3000mm)
Net Weight (lbs.)	327

Design and specifications subject to change without notice.  
Actual shipping weight may differ due to extra packing materials for product protection.

- **WARRANTY : 2 Year Parts and Labor Warranty**  
Additional 3 Year Warranty on Compressor

### STANDARD FEATURES

- Self-contained system, no plumbing required
- Safety shielded LED interior lighting
- Three color options available : stainless steel, white or black
- 3" dia. swivel casters

### Recommended operating conditions

TBP models are designed to operate in an environment where temperature & humidity do not exceed 75°F and 55% respectively.

## PLAN VIEW

(unit : inch)

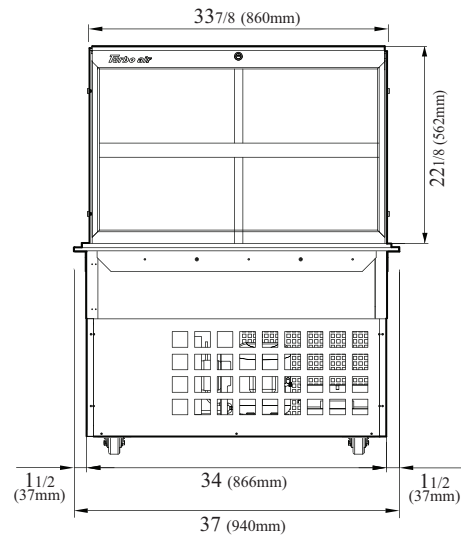

FRONT VIEW

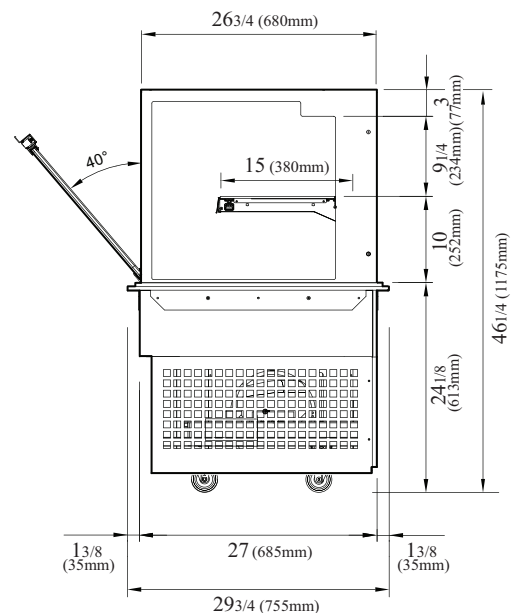

SIDE VIEW

Ver.20190403



- Turbo Air : 800-627-0032
- GK : 800-500-3519
- Warranty : 800-381-7770
- AC : 888-900-1002

